

ADVATEK

CREATE | CONNECT | CONTROL

PixLite E16-S Mk3 User Manual

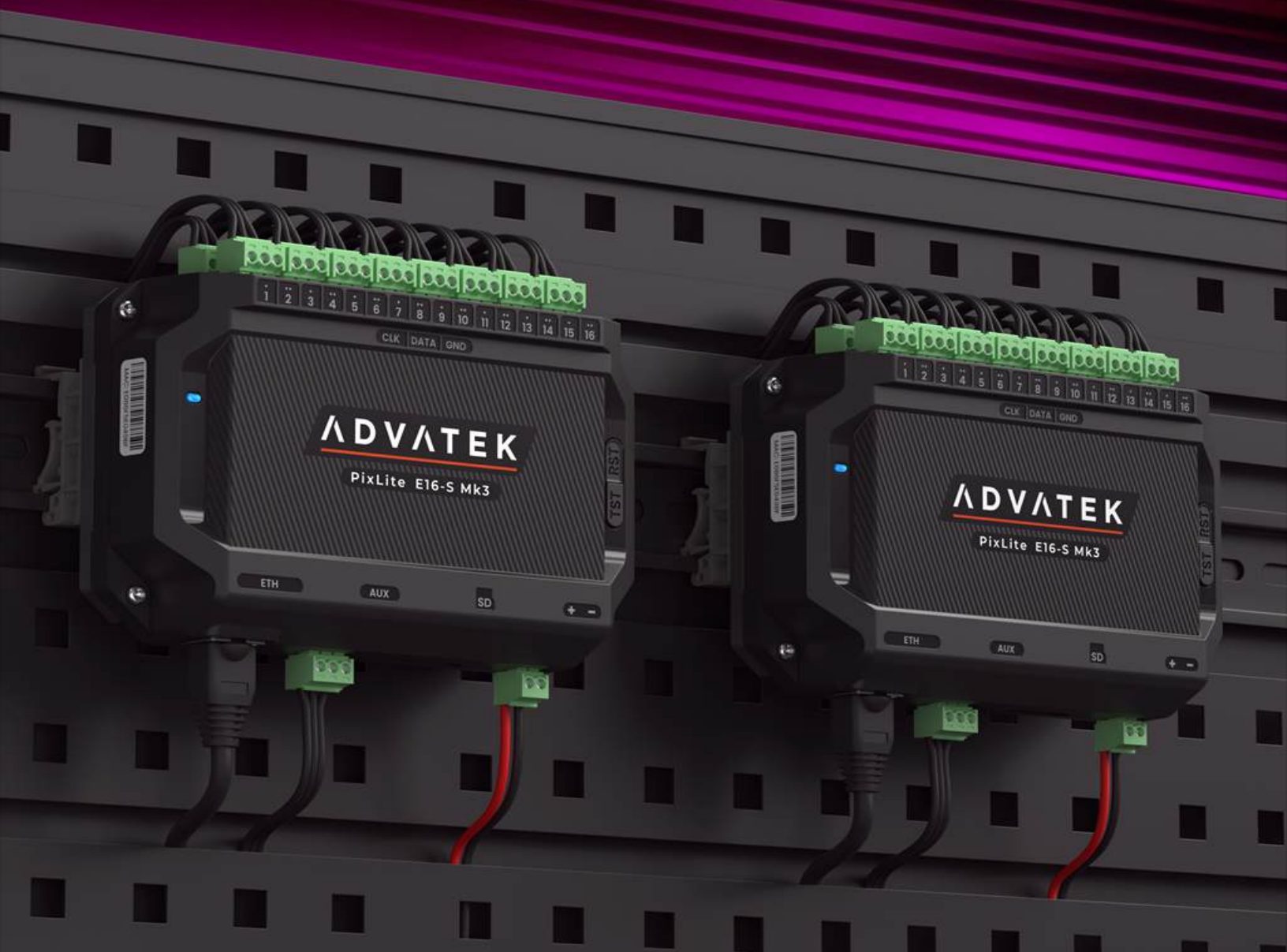

1 - Table of Contents

1 - Table of Contents	2
2 - Introduction	4
2.1 - Management & Configuration	4
3 - Safety Notes	5
4 - Physical Installation	6
4.1 - Installation Requirements	6
4.2 - Flat Surface Mount	6
4.3 - DIN Rail Mount	8
5 - Electrical Connections	11
5.1 - Supplying Power	11
5.2 - Control Data	11
5.3 - Pixel Outputs & Expanded Mode	12
5.4 - Differential DMX512 Pixels	14
5.5 - Backup Data for Select Pixels	15
5.6 - Aux Port	15
6 - Network Configuration	17
6.1 - Network Layout Options	17
6.2 - IGMP Snooping	18
6.3 - IP Addressing	18
6.3.1 - DHCP	18
6.3.2 - AutoIP	18
6.3.3 - Static IP	18
6.3.4 - Factory IP Address	19
7 - Operation	20
7.1 - Start-up	20
7.2 - Sending Ethernet Data	20
7.3 - Pixel Outputs	20
7.4 - Button Actions	20
7.5 - Hardware Test Pattern	21
7.6 - Operating Refresh Rates	21
7.7 - sACN Priorities	22
7.8 - Advatek SHOWTime	23
8 - Firmware Updates	24
8.1 - Updating via the Management Interface	24
9 - Specifications	25

9.1 - Operating Specifications	25
9.1.1 - Power	25
9.1.2 - Thermal	25
9.2 - Physical Specifications	25
9.3 - Electrical Fault Protection	26
10 - Troubleshooting	27
10.1 - LED Codes	27
10.2 - Statistical Monitoring	28
10.3 - Solutions for Common Issues	28
10.4 - Other Issues	29
10.5 - Reset to Factory Defaults	29
11 - Disclaimer	30

2 - Introduction

This is the user manual for the PixLite E16-S Mk3 pixel controller. The PixLite E16-S Mk3 is a powerful pixel LED controller built upon Advatek's 3rd generation PixLite Mk3 processor. At its core, the controller converts sACN, Art-Net and DMX512 protocols from lighting consoles, media servers or computer lighting software into various pixel LED protocols. With the PixLite Mk3 processor, the PixLite E16-S Mk3 brings powerful operational functionality and advanced management platforms.

2.1 - Management & Configuration

This manual covers physical aspects of the PixLite E16-S Mk3 controller and its essential setup steps only. Detailed information about its configuration options can be found in the 'PixLite Mk3 Management Guide'.

Configuration, management, and monitoring of this device can be performed via the web-based Management Interface. To access the interface, either open any web browser and navigate to the IP address of the device, or use Advatek Assistant 3, which can be downloaded here:

www.advateklighting.com/advatek-assistant-3

Figure 1: Management Interface Home Page

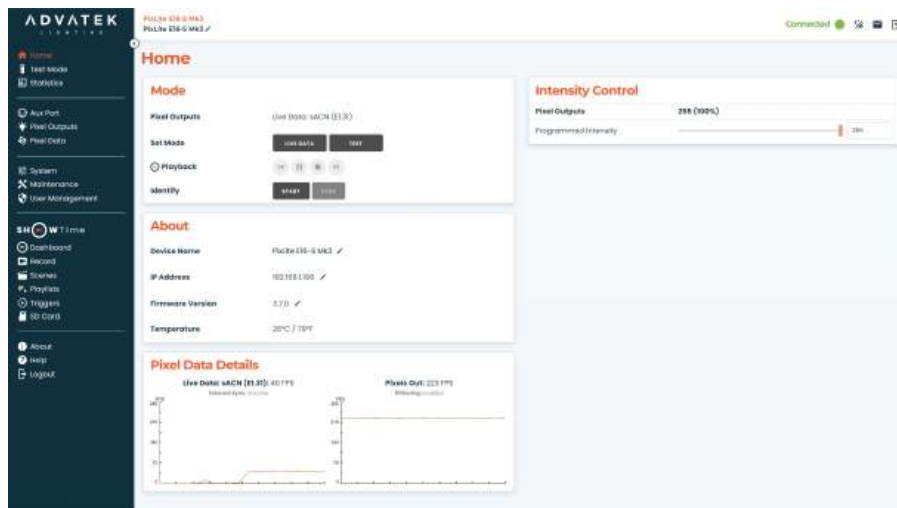

Other manuals and the PixLite Mk3 Management Guide may be downloaded from:

www.advateklighting.com/downloads

3 - Safety Notes

This LED pixel controller should be installed by someone with proper technical knowledge only. Installation of the device should not be attempted without such knowledge.

The pixel output connectors shall be used for pixel output connection only.

Completely disconnect the supply source during abnormal operation and before making any other connections to the device.

Specification and certification markings are located on the side of the device.

4 - Physical Installation

IMPORTANT NOTICE

The device warranty applies only when installed and operated in accordance with these Installation Instructions and when operated in accordance with the limits defined in the specifications.

4.1 - Installation Requirements

The unit **MUST** be installed according to the mounting methods described below.

DO NOT fasten to objects that generate heat, such as a power supply.

DO NOT install or store the device exposed to direct sunlight.

This device is suitable for indoor installation only.

Where the product has the conformal coating option, the device may be installed outdoors inside a weatherproof enclosure.

Ensure device ambient temperatures do not exceed the limits detailed in the specifications section.

4.2 - Flat Surface Mount

Assemble the unit onto the mounting surface using screws of a type suitable for the mounting surface (not supplied). The screws should be a pan head type, 3mm in thread diameter and at least 15mm long, as shown in [Figure 2](#) below.

Figure 2: Controller Assembled to Flat Surface

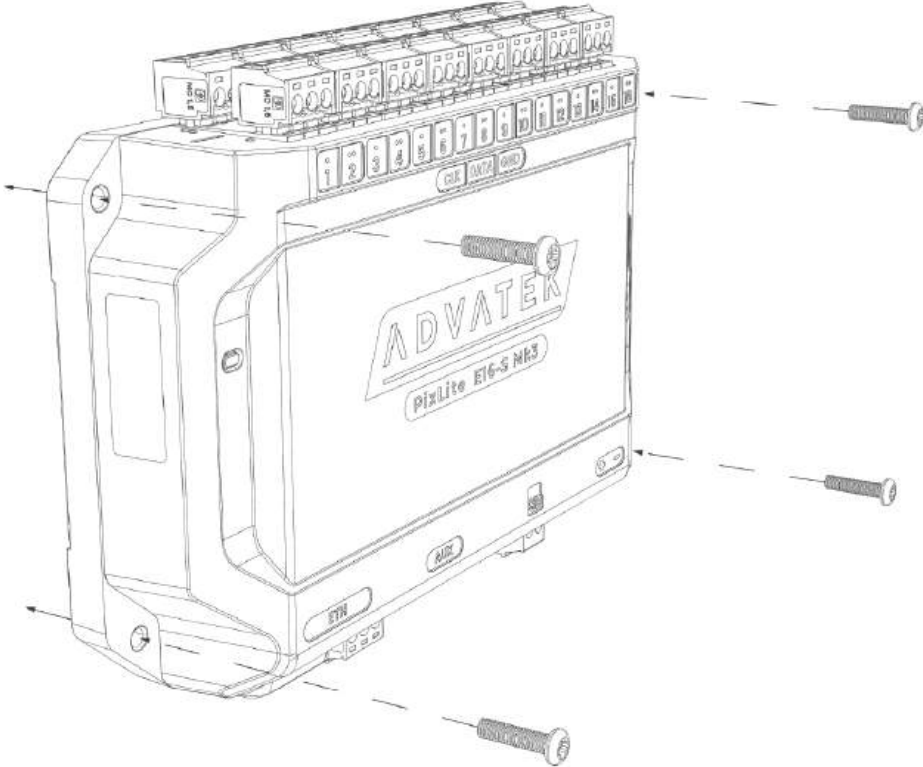

4.3 - DIN Rail Mount

The controller can be mounted to a DIN rail using the optional mounting kit (part number MNT0101).

1. Align the controller's mounting holes with the outermost mounting holes on each bracket. Using the four supplied M3, 12mm long screws, assemble the controller to the mounting brackets, as shown in [Figure 3](#) below.

Figure 3: Controller Assembled to Bracket

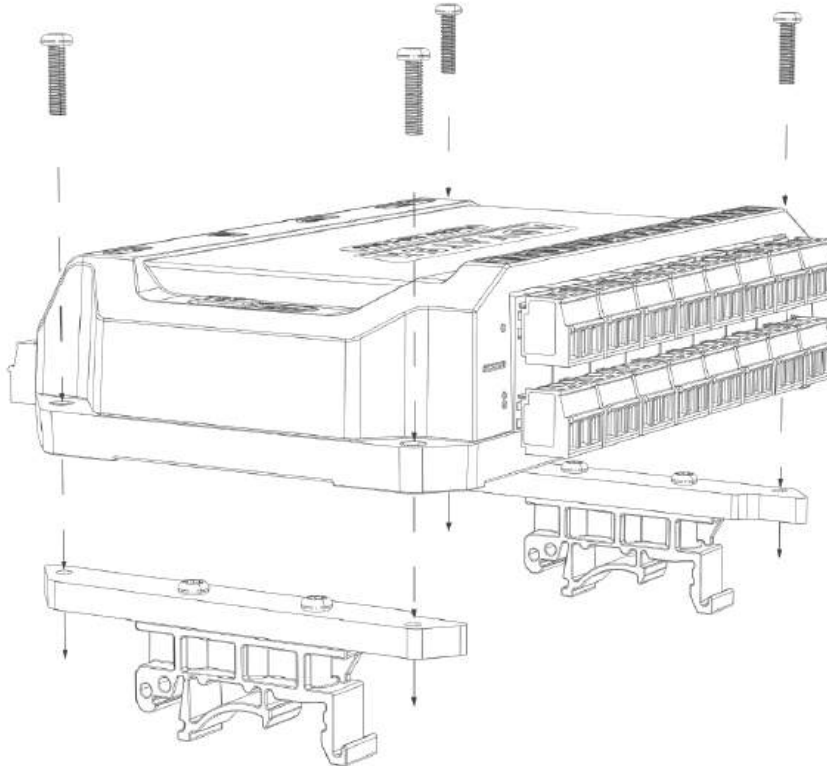

2. Align the lower edge of the bracket with the lower edge of the DIN rail (1), and push the controller down so it clicks onto the DIN rail (2), as shown in **Figure 4** below.

Figure 4: Controller Assembled to DIN Rail

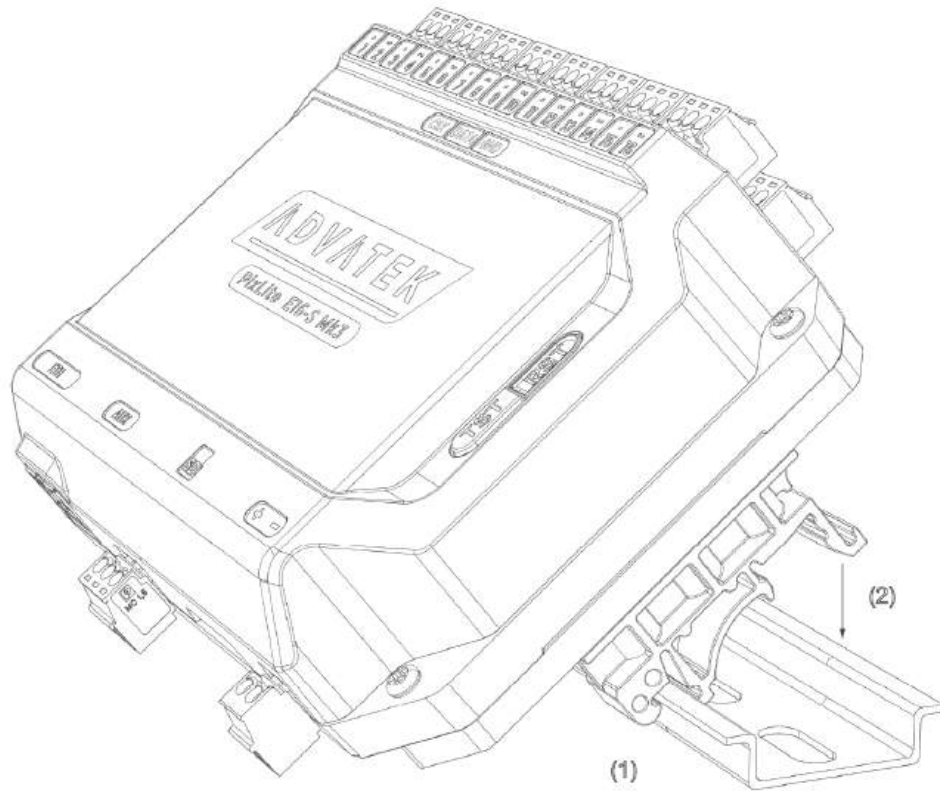

3. To remove the controller from the DIN rail, pull the controller horizontally, toward its power connector (1) while rotating the controller up and off the rail (2), as shown in **Figure 5** below.

Figure 5: Removal of Controller from DIN Rail

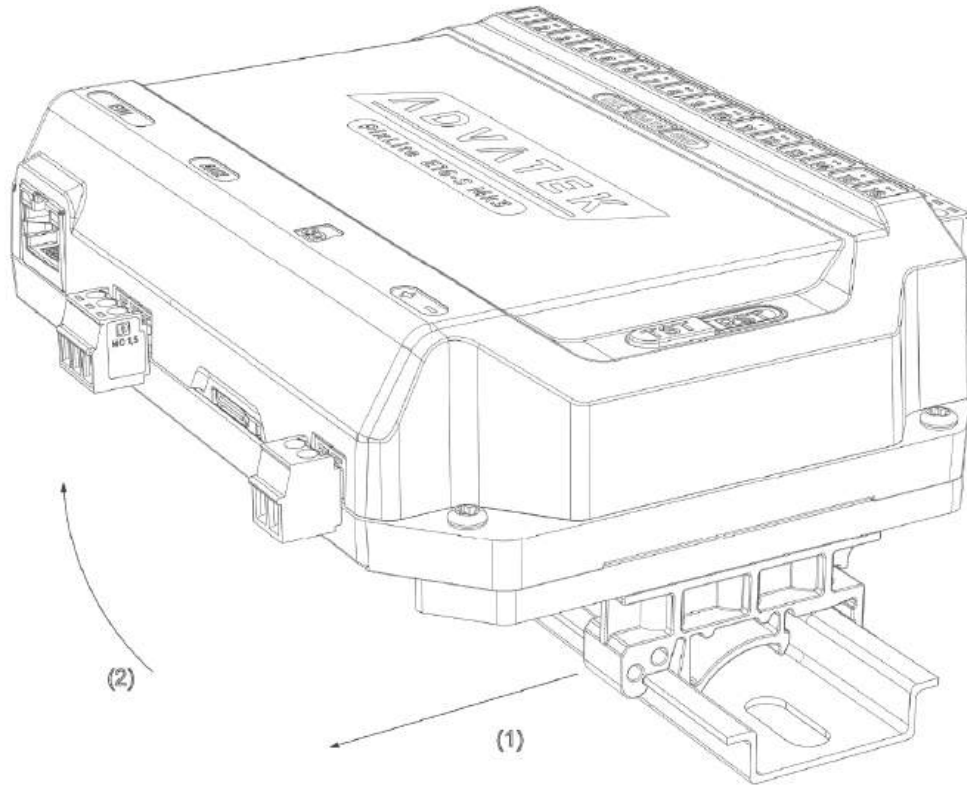

5 - Electrical Connections

5.1 - Supplying Power

Power is applied to the PixLite E16-S Mk3 via the small pluggable screw terminal connector. The screws should be loosened for wire insertion and then tightened again, providing a highly robust and secure connection. Polarity for the connector is clearly marked on the lid (“+” & “-”), as shown in [Figure 6](#) below. The type of wire required for supply connection is 1.0mm², 16AWG, VW-1.

Refer to [Section 9.1](#) for operating specifications for powering this device.

Figure 6: Location of Power Input



Pixels that are connected to the PixLite E16-S Mk3 cannot be powered through the device itself; any pixels connected must have their power sourced separately from a power supply instead. If multiple power supplies are in use, then the DC ground (also known as "negative") terminals of each power supply must be connected together, in order to achieve a common DC ground.

Advatek recommends fusing each positive line that is used to power the pixels, using an in-line fast blow fuse.

5.2 - Control Data

Ethernet data is connected via a standard network cable into the RJ45 Ethernet port located on the front side of the unit, as shown in [Figure 7](#) below.

Figure 7: Position of Ethernet



5.3 - Pixel Outputs & Expanded Mode

A high level wiring diagram for connecting pixel LEDs to a PixLite E16-S Mk3 is shown in [Figure 8](#) below. Refer to [Section 7.3](#) for the specific capacity of a pixel output.

Figure 8: Pixel Set up

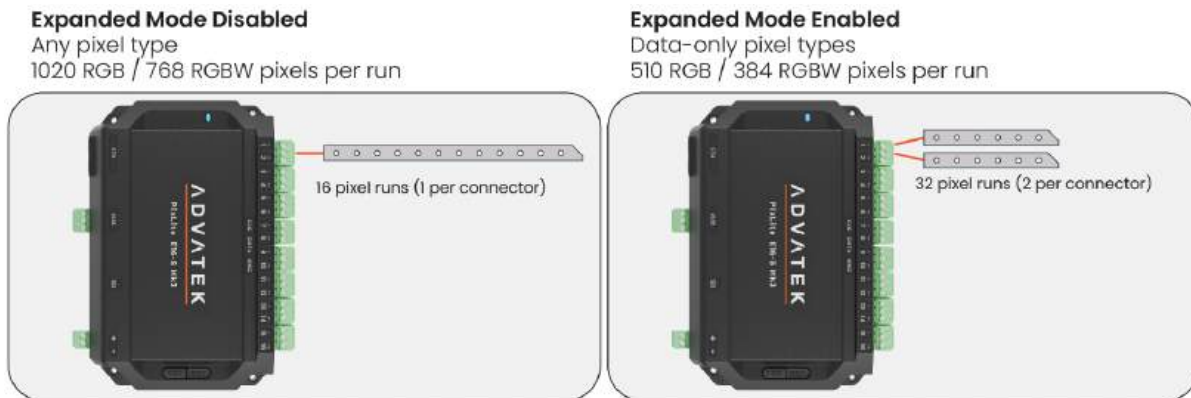

The pixel lights are connected directly via the 16 pluggable screw terminal connectors on the rear of the unit. Each connector is labelled with its output channel number (1-16) which is clearly marked on the top surface. Simply wire your lights into each screw terminal and then plug them into the mating sockets.

The cable length between the output and the first pixel should not exceed 15m.

[Figure 9](#) shows the pin-out of the pixel output connectors.

Figure 9: Pixel Output Pinout - Expanded Mode Disabled

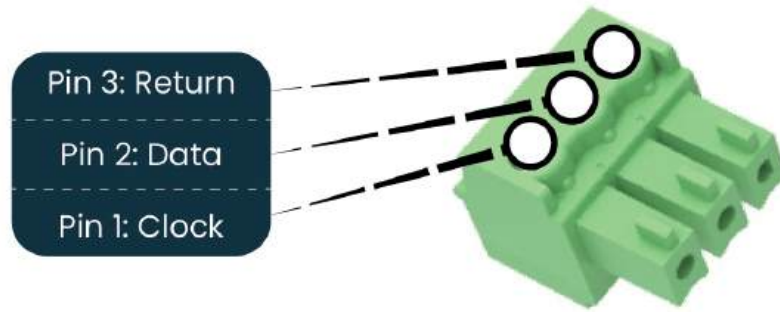

By default, a PixLite controller will have expanded mode disabled. In this state, each physical output corresponds to its numbered output in the management interface. This is explained in the table below.

Expanded Mode Disabled

Logical Output	Physical Output
1	1
2	2
3	3
4	4
etc.	

If your pixels only use a single data line, you may optionally activate expanded mode on the controller, via the Management Interface. In expanded mode, the clock pins are used for data signals instead. This means the controller effectively has twice as many pixel outputs (32), but half as many pixels per output can be run.

Expanded mode can help increase flexibility in a system as there are more outputs available. It can also assist by spreading out the number of controlled pixels across more outputs, which can help achieve higher refresh rates if clocked pixels aren't being used.

When expanded mode is enabled, the outputs in the management interface instead map like the following:

Expanded Mode Enabled

Logical Output	Physical Output	Output Pin Name
1	1	Clock
2	1	Data
3	2	Clock
4	2	Data
5	3	Clock
6	3	Data
7	4	Clock
8	4	Data
etc.		

The pinout for expanded mode is shown in [Figure 10](#) below.

Figure 10: Pixel Output Pinout - Expanded Mode Enabled

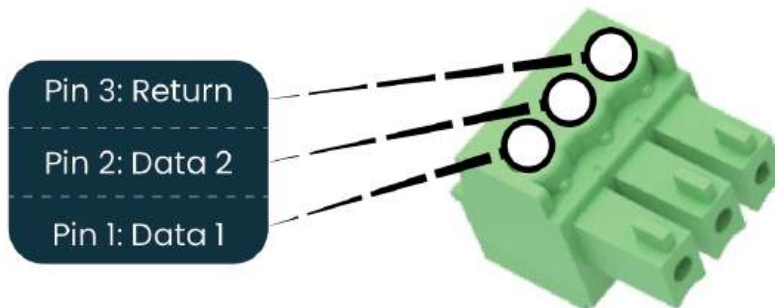

5.4 - Differential DMX512 Pixels

The PixLite E16-S Mk3 can connect to differential DMX512 pixels, as well as single-wire serial DMX512 pixels. Single wired DMX512 pixels can connect as per the pinout above. Differential DMX512 pixels require connection of an additional data wire. This pinout can be seen in [Figure 11](#) below.

Notes:

When driving differential DMX512 pixels, you should ensure that the data transmission speed is set appropriately, based on the specification of your pixels. The standard speed for DMX512 transmission is 250kHz, however many DMX pixel protocols can accept faster speeds.

With DMX pixels, the outgoing data stream is not limited to a single universe, as a standard DMX universe would be.

When connected to a PixLite E16-S Mk3, the maximum number of DMX512-D pixels that can be configured is the same as if expanded mode were enabled, which is 510 RGB pixels per output.

Figure 11: Pixel Output Pinout for Differential DMX512 Pixels

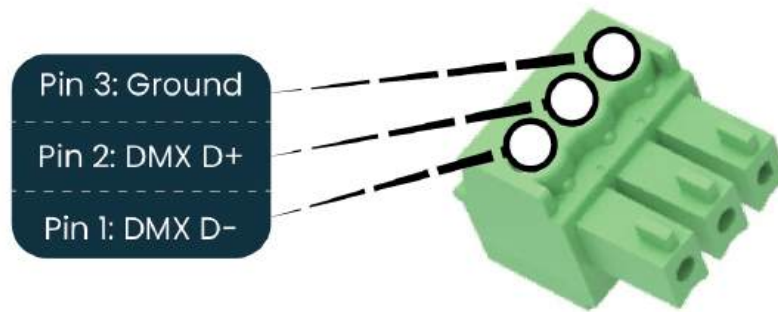

5.5 - Backup Data for Select Pixels

Many pixels with a backup data input do not require it to be connected to the PixLite, however some select pixel types require a backup line to be connected to a secondary source of data, which generates a modified version of the original data signal. Without this connection, the first few pixels in a run will not operate correctly. For these select pixels, the backup wire must be connected to the "Clock" pin on the pixel output, which provides this modified data signal. See pixel glossary on the Advatek website to confirm pixels which require a backup connection to the PixLite.

This pinout can be seen in [Figure 12](#) below.

Note: The maximum number of these pixels per output is the same as if expanded mode were enabled, which is 510 RGB pixels per output.

Figure 12: Pixel Output Pinout for Select Backup Pixels

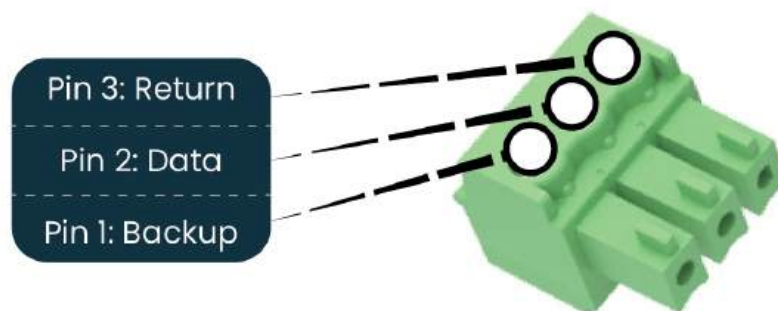

5.6 - Aux Port

The PixLite E16-S Mk3 has 1 multipurpose auxiliary (Aux) port that can be used for DMX512 communication using RS485 electrical signals. It is capable of outputting DMX512 to other devices or receiving DMX512 from another source.

Configure the Aux port to DMX512 Output to allow conversion of a single universe of incoming sACN or Art-Net data to the DMX512 protocol. This then allows any DMX512 device(s) to be

connected to this port and effectively be controllable over Ethernet. SHOWTime scenes can also contain Aux data, which effectively allows you to playback DMX512 data to DMX512 fixtures.

Configure the Aux port to DMX512 Input to allow the following two features:

- Drive connected pixels by an external source of DMX512 control. Whilst this is limited to only a single universe of data, the PixLite can use DMX512 as its source of pixel data for situations where a DMX512 control system is required to be used instead of Ethernet-based data.
- Use DMX512 as a source of triggering. This allows a DMX512 control system to trigger the PixLite to perform actions like playback of a scene, and more. For more information on triggering, see the PixLite Mk3 Management Guide here:

www.advateklighting.com/product-help/pixlite/mk3/management-guide

The Aux port connector is located on the front side of the unit as shown in **Figure 13** below.

Figure 13: Location and Pinout of the Aux Port



6 - Network Configuration

6.1 - Network Layout Options

Figure 14: Network Layout using a Switch and Router

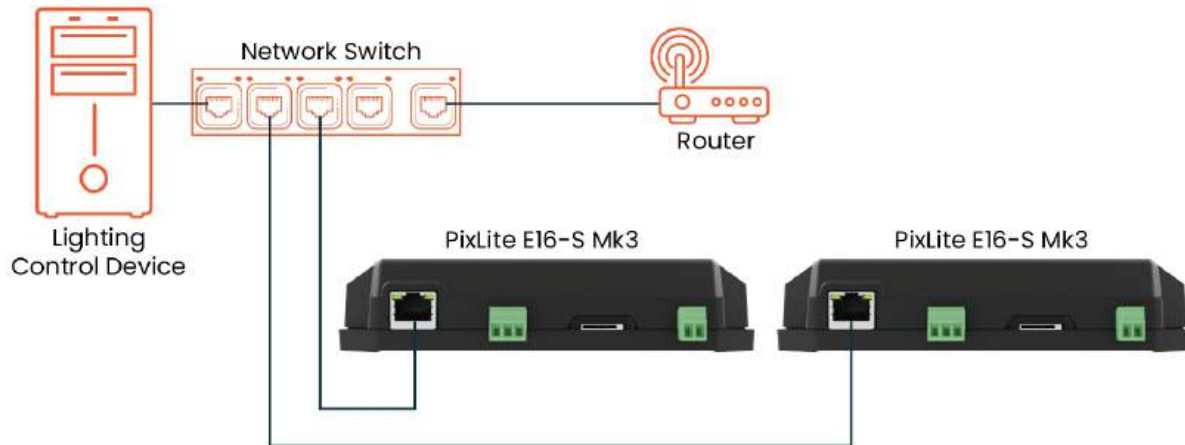

Figure 14 shows a typical network topology for the PixLite E16-S Mk3.

The Lighting Control Device could be any source of Ethernet data - e.g. desktop PC, laptop, lighting console, or media server.

Having a router on the network is not mandatory but is useful for IP address management with DHCP (see Section 6.3.1).

Figure 15: Network Layout Without a Switch/Router



The controller can alternatively be connected directly to the host machine, as shown in Figure 15. A crossover cable is not required in this case, but it may be used if desired.

The controller(s) can be integrated straight into any pre-existing LAN such as your media, home or office network, the above diagrams are only provided as examples.

6.2 - IGMP Snooping

Installations using multicast sACN will benefit from the use of IGMP Snooping enabled network equipment when there are more multicast universes on the network than any one PixLite is using. If there are more than 96 universes of multicast sACN on the network then IGMP Snooping is mandatory.

Note: "E" Series devices are not equipped with a Universe Data Hardware Firewall, which many other PixLite Mk3 devices have. This feature removes the need for IGMP Snooping. This means that operation of the PixLite E16-S Mk3 in the situation described above will require IGMP Snooping, as there is no hardware firewall in place.

6.3 - IP Addressing

6.3.1 - DHCP

Routers typically have an internal DHCP server, which means they can assign an IP address to a connected device, if requested.

DHCP is always enabled by default on this device, so it can immediately connect to any existing network with a router / DHCP Server. If the controller is in DHCP mode and is not assigned an IP address by a DHCP server, it will assign itself an IP address with Automatic IP Addressing, as explained in [Section 6.3.2](#) below.

6.3.2 - AutoIP

When this device has DHCP enabled (factory default), there is also functionality for it to be operational on networks without a DHCP server, via the AutoIP mechanism.

When no DHCP address is being offered to this device it will generate a random IP address in the range of 169.254.X.Y that does not conflict with any other devices on the network. The benefit of AutoIP is that communication can happen between the device and any other compatible network device, without the need for a DHCP server or pre-configured Static IP addressing.

This then means that connecting a PixLite E16-S Mk3 directly to a PC typically does not require any IP address configuration - communication will be possible because both devices would generate their own valid AutoIP.

While the device has an AutoIP address in use, it continues searching for a DHCP address in the background. If one becomes available, it will switch to the DHCP address instead of the AutoIP.

6.3.3 - Static IP

In many typical lighting networks that this device would operate in, it's common for the installer to manually manage a set of IP addresses, instead of relying on DHCP or AutoIP. This is referred to as static network addressing.

When allocating a static address, the IP address and the subnet mask both define the subnet that the device is operating on. You need to ensure that other devices that need to communicate with this device are on the same subnet. Therefore they should have the same subnet mask and a similar but unique IP address.

When setting static network settings, the Gateway address can be set to 0.0.0.0 if it is not required. If communication between the device and other VLANs is required, the Gateway address should be configured and will typically be the IP address of the router.

6.3.4 - Factory IP Address

When you are not sure what IP address the device is using, you can force it to use a known IP address (referred to as the Factory IP).

To activate the Factory IP and establish communication with the device:

1. While the controller is running, hold down the "Reset" button for 3 seconds.
2. Release the button.
3. The controller will immediately restart its application with the following factory default network settings:

IP Address:	192.168.0.50
Subnet Mask:	255.255.255.0
Gateway Address:	0.0.0.0
4. Configure your PC with compatible network settings. If you are not sure, you can try the following example settings:

IP Address:	192.168.0.49
Subnet Mask:	255.255.255.0
Gateway Address:	0.0.0.0
5. You should now be able to access the device's Management Interface by manually browsing to 192.168.0.50 in your web browser, or by using Advatek Assistant 3.

After establishing a connection to the device, make sure to configure the IP address settings for future communication and save the configuration.

Note: The Factory IP is only a temporary setting used to regain connectivity to the device. When the device is reset (powered off and on again), the IP address settings will revert to what is configured in the device.

7 - Operation

7.1 - Start-up

Upon applying power, the controller will quickly begin outputting data to the pixels. If no data is being sent to the controller, then the pixels will remain turned off until valid data is received. During live mode, the multi color status LED will be flashing green to indicate the controller is running and outputting any received data to the pixels.

7.2 - Sending Ethernet Data

Input data is sent from the control PC/server/lighting console to the controller via Ethernet using a "DMX over IP" protocol such as sACN (E1.31) or Art-Net. This device will accept Art-Net or sACN data on either Ethernet port.

Sync modes are supported for both Art-Net and sACN. To learn more, refer to the technical note on synchronous mode here:

www.advateklighting.com/knowledge-base

Details of incoming and outgoing packets can be viewed in the Management Interface.

7.3 - Pixel Outputs

Each of the 16 pixel outputs on the PixLite E16-S Mk3 can drive up to 6 universes of data. This allows for a total of up to 96 universes of pixel data to be driven out of the one controller. The number of pixels that can be driven per pixel output will depend on the configuration, as shown in the table below.

Expanded Mode Color Type	Disabled			Enabled		
	RGB	RGBW	RGBCCT	RGB	RGBW	RGBCCT
Max Pixels per Pixel Output	1,020	768	612	510	384	308
Max Total Pixels	16,320	12,288	9,792	16,320	12,288	9,792

The PixLite must be configured before it can correctly output pixel data. Refer to the PixLite Mk3 Management Guide for how to configure and patch your pixel outputs.

7.4 - Button Actions

The 'Test' and 'Reset' buttons can be used to perform various operations, as listed below.

Action	Test Button	Reset Button
Toggle Test Mode On/Off	Press for >3 seconds while the application is running	-
Cycle the Test Modes	Press whilst in test mode	-
Hardware Reset	-	Press momentarily
Factory Reset	-	Press for >10 seconds
Factory IP	-	Press for 3 seconds

7.5 - Hardware Test Pattern

The controller features a built-in test pattern to assist in troubleshooting during an installation. To put the controller into this mode, press and hold the 'TEST' button for 3 seconds (after the controller is already running) or turn it on remotely using its Management Interface.

The controller will then enter the test pattern mode, where different test patterns are available as described in the table below. The controller will display the test pattern on all pixels on each of the pixel outputs and the Aux DMX512 output (if enabled) simultaneously. Pressing the 'TEST' button while in test mode will move through each of the patterns successively in one continuous loop.

Test	Operation
Color Cycle	Automatic cycle through the available color channels in sequence. <i>Pressing the TEST button moves to the next mode.</i>
Red	Solid Red.
Green	Solid Green.
Blue	Solid Blue.
All On	All channels set to full.
RGB Fade	Automatically fade through the RGB color wheel. <i>Pressing the TEST button will loop back to the original color cycle test mode.</i>

To exit the test mode, press and hold the 'TEST' button for 3 seconds and then release.

The hardware test requires that the pixel driver chip type and number of pixels per output are set correctly in the Management Interface. Using Test mode, you can test if this part of your configuration is correct and isolate other possible problems with the incoming Ethernet data side.

7.6 - Operating Refresh Rates

The overall refresh rate of an installed pixel system will depend on many factors. For monitoring purposes, graphical and numerical information on incoming and outgoing frame rates can be viewed in the Management Interface. This information gives insight as to what refresh rate a system can achieve, and where any limiting factors may exist.

Refresh rates are available in the Management Interface for each of the following elements:

- Incoming sACN
- Incoming Art-Net
- Incoming DMX512 (Aux Port)
- Outgoing Pixels
- Outgoing DMX512 (Aux Port)

7.7 - sACN Priorities

It is possible to have multiple sources of the same sACN universe received by the one PixLite. The source with the higher priority will be actively streaming to the pixels, and this can be seen on the Statistics page. This is useful for situations where a backup data source is needed.

For this to take place, the PixLite still needs to receive and process each universe, including universes that will be dropped due to a lower priority.

Low priority sACN handling with the PixLite E16-S Mk3 will require that the total number of universes being streamed to the controller from all sources combined, for any purpose, should not exceed 100 universes.

7.8 - Advatek SHOWTime



Advatek SHOWTime™ unleashes the potential of Advatek PixLite® Mk3 devices to independently drive light shows without a computer or any source of live data.

SHOWTime™ allows users to record and play back pixel shows from the PixLite E16-S Mk3 using the inbuilt microSD slot. Design your own breathtaking pixel shows, record them directly onto the microSD card and play them back as many times as you wish.

SHOWTime™ also unlocks the ability to create up to 25 powerful triggers and use advanced intensity controls to enable true standalone behavior and enhance live environments.

Experience a new level of control with the dual-user login feature and a dedicated SHOWTime™ Dashboard. Now, operators can access real-time playback and device control through the SHOWTime™ Dashboard, amplifying the flexibility of PixLite Mk3.

For more information, download the PixLite Mk3 Management Guide here:

www.advateklighting.com/product-help/pixlite/mk3/management-guide

8 - Firmware Updates

The controller is capable of having its firmware updated (new software). An update is typically performed to fix problems or to add new features.

To perform a firmware update, ensure that you have your PixLite E16-S Mk3 controller connected to the LAN network as per [Section 6.1](#).

The latest firmware is available from the Advatek website at the following link:

www.advateklighting.com/downloads

The downloaded file will be archived in a ".zip" format, which should be extracted. The ".fw" file is the file that the controller needs.

8.1 - Updating via the Management Interface

1. Open the Management Interface, and navigate to the "Maintenance" page.
2. Load the firmware ".fw" file with the file browser.
3. Click "Update". The controller will temporarily disconnect.
4. Once the update is complete, the controller will restart its application with the new firmware, maintaining its previous configuration.

9 - Specifications

9.1 - Operating Specifications

The table below specifies the operating conditions for a PixLite E16-S Mk3 controller.

For a full list of specifications, refer to the product datasheet.

9.1.1 - Power

Parameter	Value/Range	Units
Input Power	5 - 24	V DC
Maximum Power Consumption	3.5	W

9.1.2 - Thermal

Parameter	Value/Range	Units
Ambient Operating Temperature	-20 to +70	°C
Storage Temperature	-20 to +70	°C

9.2 - Physical Specifications

Dimension	Metric	Imperial
Length	149.5mm	5.89"
Width	114.5mm	4.51"
Height	35.5mm	1.40"
Weight	0.2kg	0.4lbs

Figure 16: Mechanical Specifications

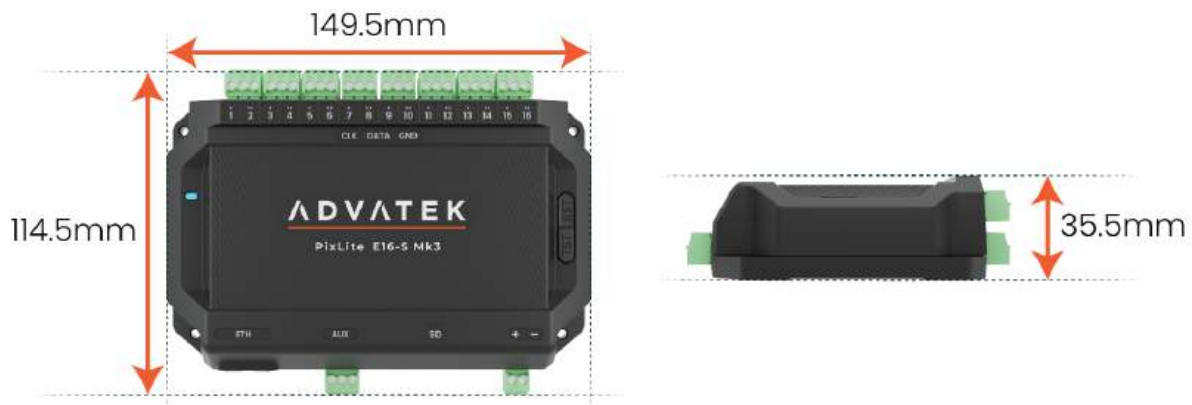

9.3 - Electrical Fault Protection

The PixLite E16-S Mk3 features notable protection from potential damage due to various types of faults. This makes the device robust and reliably able to operate in the suitable installation environment, specified in [Section 11](#).

ESD protection is present on all ports.

All pixel outputs are protected against faults of up to +/- 36V DC.

The Aux Port is protected against faults of up to +/- 48V DC.

The PixLite E16-S Mk3 is protected against damage from reversed polarity power input.

10 - Troubleshooting

10.1 - LED Codes

There are multiple LEDs on the PixLite E16-S Mk3 that are useful for troubleshooting. The location of each is shown in [Figure 17](#) below.

Figure 17: Location of LEDs



Please refer to the tables below for condition codes for the Ethernet port LEDs, and the multi-color status LED.

Link LED (Green)	Activity LED (Yellow)	Condition
Solid	Flashing	Connected okay, receiving / transmitting data
Solid	Off	Connected okay, no data
Off	Off	No link established

Color(s)	Behavior	Description
Green	Flashing	Normal Operation
Red	Flashing	Record in Progress
Blue	Flashing	Playback in Progress
Yellow	Flashing (3 per second)	Identify Function (used to visually locate a device)
Red/Green/Blue/White	Cycling	Test Mode - Color Cycle
Color Wheel	Cycling	Test Mode - RGB Fade
Various	Solid	Test Mode - Set Color
Orange	Flashing	Remote Test Mode Active
Blue/Yellow	Alternating	Impaired State (Current mode cannot function)
Green	Solid	Booting Up or Installing Firmware
White	Flashing	Factory Reset
Green/Red	Alternating	Emergency Recovery Mode
Off	Off	No Power / Hardware Fault
White	Flashing (3 per 5 sec)	Power Supply Stability Error Detected (power device off and on again)
Red/White	Various	Critical Error (contact Advatek Support)

10.2 - Statistical Monitoring

Many issues that may occur are often due to complications in the network, configuration, or wiring. For this reason, the Management Interface features a statistics page for statistical monitoring and diagnostics. Refer to the PixLite Mk3 Management Guide for more information.

10.3 - Solutions for Common Issues

Issue	Suggested Solution
Status LED off	<ul style="list-style-type: none"> Ensure that your power supply is supplying correct voltage as per Section 5.1. Disconnect all cables from the device, except for the power input, to see if the device turns on.
No pixel control	<ul style="list-style-type: none"> Ensure the device has been configured correctly, with the correct Pixel Type and number of Pixels set. Activate a test pattern as per Section 7.5 to see if your pixels turn on. Check that the physical wiring and pinout of the pixels are correctly connected and are in the correct positions, as per Section 5. As the pixels are required to be powered and protected externally to the controller, the voltage to the pixels should be measured with a voltage measurement tool. The voltage at the pixels should be within operating specifications of the pixels.

10.4 - Other Issues

Check the LED codes as per [Section 10.1](#). If the device still fails to perform as expected, perform a factory default reset on the device as per [Section 10.5](#) below. For the latest information, more specific troubleshooting guides and other help, you should refer to our online Knowledge Base here:

www.advateklighting.com/knowledge-base

Alternatively, you can contact our support team at:

www.advateklighting.com/contact

support@advateklighting.com

10.5 - Reset to Factory Defaults

To reset the controller to its factory default settings, do the following:

1. Ensure the controller is powered up.
2. Hold down the 'Reset' button for 10 seconds.
3. Wait for the Multi-Color Status LED to alternate Green/White.
4. Release the 'Reset' button. The controller will now have factory default configuration.
5. Alternatively, reset to factory defaults via the Management Interface, in the "Configuration" page.

Note: This process will reset all configuration parameters to Factory Defaults, including IP Address settings (listed in [Section 6.3.4](#)), as well as Security settings.

11 - Disclaimer

If you require support or warranty, please refer to [Section 10.4](#) for information on creating a support ticket. You must be issued with a return authorization by Advatek support staff before returning any product.

This device is only suitable for use in accordance with the specifications. This device is only suitable for use in an indoor environment which is protected from the weather unless a conformal coating option has been selected. In case of products protected by conformal coating, the device can be used outdoors, provided it is protected from the weather using an enclosure suitable for the environment.

A shielded Ethernet cable is required when connecting to the Ethernet port.

The PixLite E16-S Mk3 controller is supplied with a 5-year limited warranty and a repair/replacement guarantee. Please see the terms and conditions on our website for more information.

The PixLite E16-S Mk3 has been tested against and independently certified as compliant with the standards and directives listed in the table below.

Audio/Video and ICTE - Safety Requirements		UL 62368-1
Radiated Emissions		EN 55032 & FCC Part 15
Multimedia Immunity EN 55035	Electrostatic Discharge	EN 61000-4-2
	Radiated Immunity	EN 61000-4-3
	Electrical Fast Transients/ Burst	EN 61000-4-4
	Conducted Immunity	EN 61000-4-6
Restriction of Hazardous Substances		RoHS 2 + DD (EU) 2015/863 (RoHS 3)

Through testing to the above standards, the PixLite E16-S Mk3 has the certifications and marks listed in the table below.

Certification	Relevant Country
ETL Listing (UL 662368-1)	North America and Canada
CE	Europe
FCC	North America
ICES3	Canada
RCM	Australia and New Zealand
UKCA	United Kingdom

Warning: Changes or modifications to this unit not expressly approved by the party responsible for compliance could void the user's authority to operate the equipment.

Note: This equipment has been tested and found to comply with the limits for a Class A digital device, pursuant to part 15 of the FCC Rules. These limits are designed to provide reasonable protection against harmful interference when the equipment is operated in a commercial environment. This equipment generates, uses and can radiate radio frequency energy and, if not installed and used in accordance with the instruction manual, may cause harmful interference to radio communications. Operation of this equipment in a residential area is likely to cause harmful interference in which case the user will be required to correct the interference at their own expense.

Art-Net™ Designed by and Copyright Artistic Licence Holdings Ltd.

This product has been manufactured by:

Advatek Lighting Pty Ltd
U1, 3-5 Gilda Court
Mulgrave, 3170
VIC, AUSTRALIA