

# ADVATEK

CREATE | CONNECT | CONTROL

## PixLite R4D-S User Manual

Hardware Rev 1.3



# 1 - Table of Contents

---

<b>1 - Table of Contents</b> .....	<b>2</b>
<b>2 - Introduction</b> .....	<b>3</b>
<b>3 - Safety Notes</b> .....	<b>4</b>
<b>4 - Physical Installation</b> .....	<b>5</b>
4.1 - Installation Requirements .....	5
4.2 - Flat Surface Mount .....	5
4.3 - DIN Rail Mount .....	7
<b>5 - Electrical Connections</b> .....	<b>10</b>
5.1 - Supplying Power .....	10
5.2 - Output Fuses .....	10
5.3 - Data Input .....	11
5.4 - Connecting Pixel LEDs .....	12
<b>6 - Operation</b> .....	<b>13</b>
6.1 - Start-up .....	13
6.2 - Indicator LEDs .....	13
6.3 - Outputs .....	14
<b>7 - Specifications</b> .....	<b>15</b>
7.1 - Operating Specifications .....	15
7.2 - Mechanical Specifications .....	15
7.3 - Fault Protection .....	16
<b>8 - Troubleshooting</b> .....	<b>17</b>
8.1 - No Power LED .....	17
8.2 - No Pixel Control .....	17
8.3 - Other Issues .....	17
<b>9 - Disclaimer</b> .....	<b>18</b>

## 2 - Introduction

This is the user manual for the PixLite R4D-S pixel receiver.

The PixLite R4D-S is designed to receive differential long distance signals of up to 300m (1000') from a PixLite T-Series transmitter unit, and convert these input signals back into a pixel-ready signal for output directly to pixels. The PixLite R4D-S features 4 data-only pixel outputs, each having both a dedicated fuse and 'fuse good' LED indicator.

The PixLite R4D-S features a sleek, compact design and 4 holes for ease of surface mounting as well as an optional DIN rail mounting kit. It also features industrial grade protection on all inputs and outputs, making it the ideal option for reliable commercial and industrial applications.

This manual covers physical aspects of the PixLite R4D-S receiver and its essential setup steps only. Separate user manuals are available for the transmitter units. Other manuals may be downloaded from here:

[www.advateklighting.com/downloads](http://www.advateklighting.com/downloads)

## 3 - Safety Notes

This LED pixel receiver should be installed by someone with proper technical knowledge only. Installation of the device and/or replacement of pixel output fuses should not be attempted without such knowledge.

Specification and certification markings are located on the base of the device.

# 4 - Physical Installation

## IMPORTANT NOTICE

The device warranty applies only when installed and operated in accordance with these Installation Instructions and when operated in accordance with the limits defined in the specifications.

## 4.1 - Installation Requirements

The unit **MUST** be installed according to the mounting methods described below.

DO NOT fasten to objects that generate heat, such as a power supply.

DO NOT install or store the device exposed to direct sunlight.

This device is suitable for indoor installation only.

Where the product has the conformal coating option, the device may be installed outdoors inside a weatherproof enclosure.

Ensure device ambient temperatures do not exceed the limits detailed in the specifications section.

## 4.2 - Flat Surface Mount

Assemble the unit onto the mounting surface using four screws of a type suitable for the mounting surface (not supplied). The screws should be a pan head type, 3mm in thread diameter and at least 15mm long, as shown in [Figure 1](#) below.

Figure 1: Receiver Assembled to Flat Surface

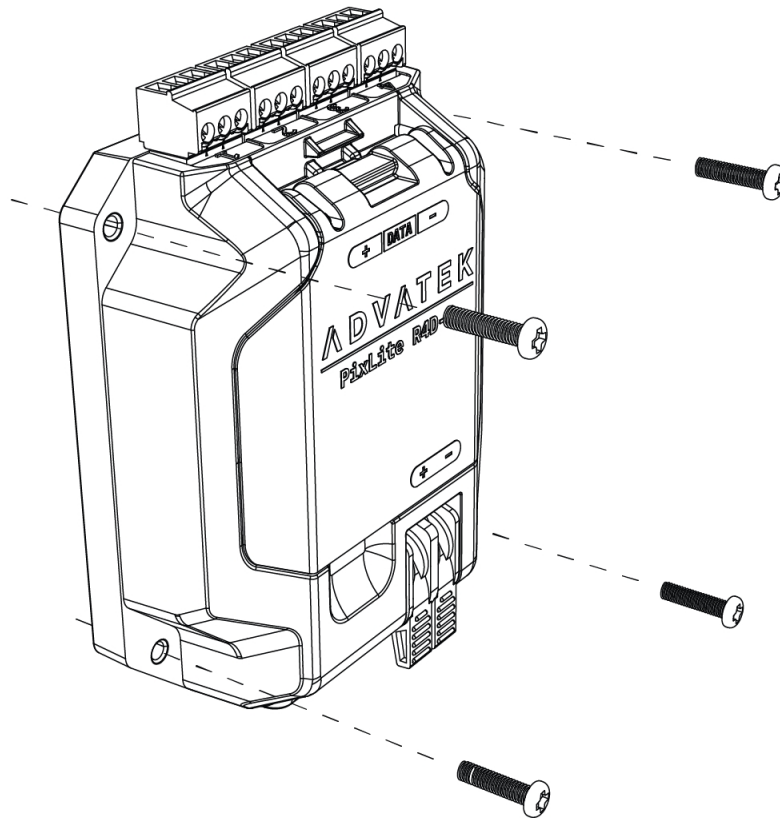

## 4.3 - DIN Rail Mount

The receiver can be mounted to a DIN rail using the optional mounting kit (part number MNT0101).

1. Align the receiver's mounting holes with the outermost mounting holes on each bracket. Using the four supplied M3, 12mm long screws, assemble the receiver to the mounting brackets, as shown in [Figure 2](#) below.

*Figure 2: Receiver Assembled to Bracket*

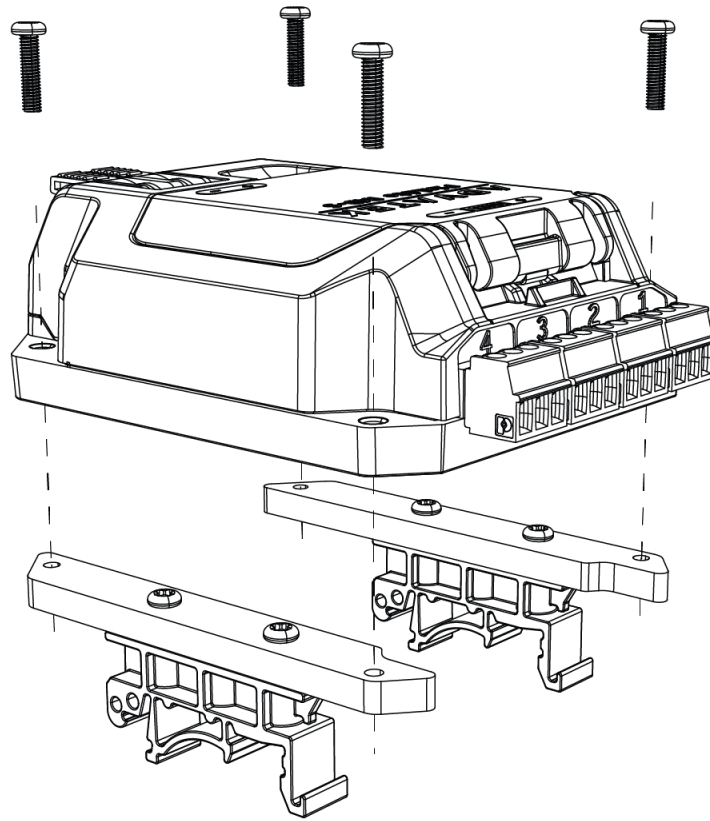

2. Align the lower edge of the bracket with the lower edge of the DIN rail (1), and push the receiver down so it clicks onto the DIN rail (2), as shown in **Figure 3** below.

*Figure 3: Receiver Assembled to DIN Rail*

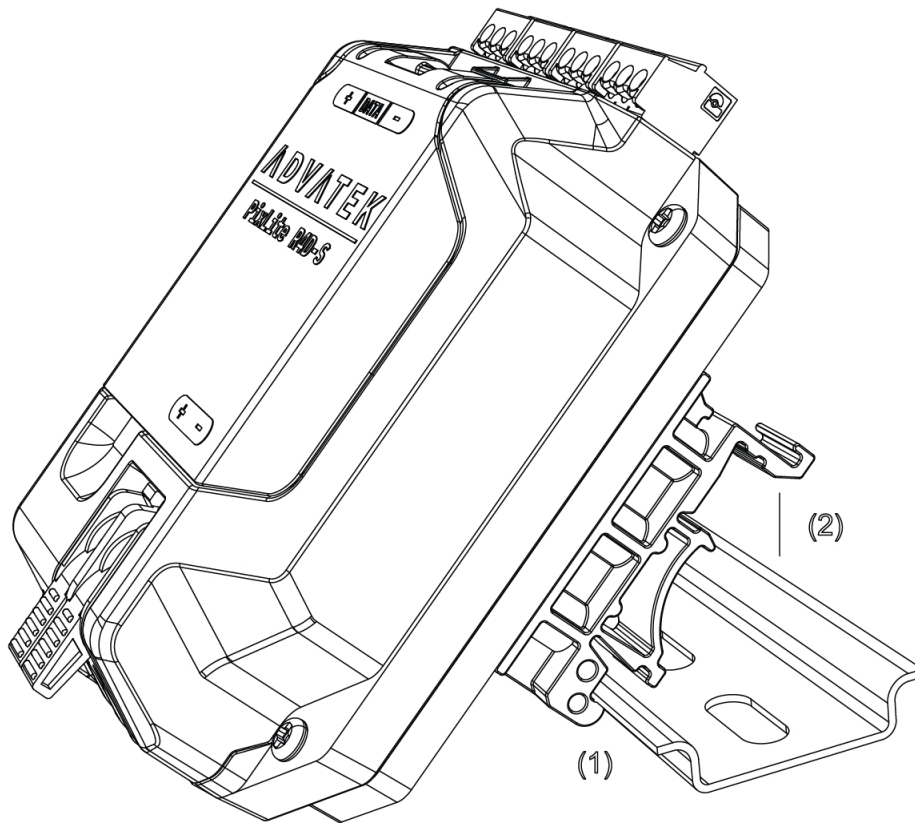

3. To remove the receiver from the DIN rail, pull the receiver horizontally, toward its power connector (1) while rotating the receiver up and off the rail (2), as shown in **Figure 4** below.

*Figure 4: Removal of Receiver from DIN Rail*

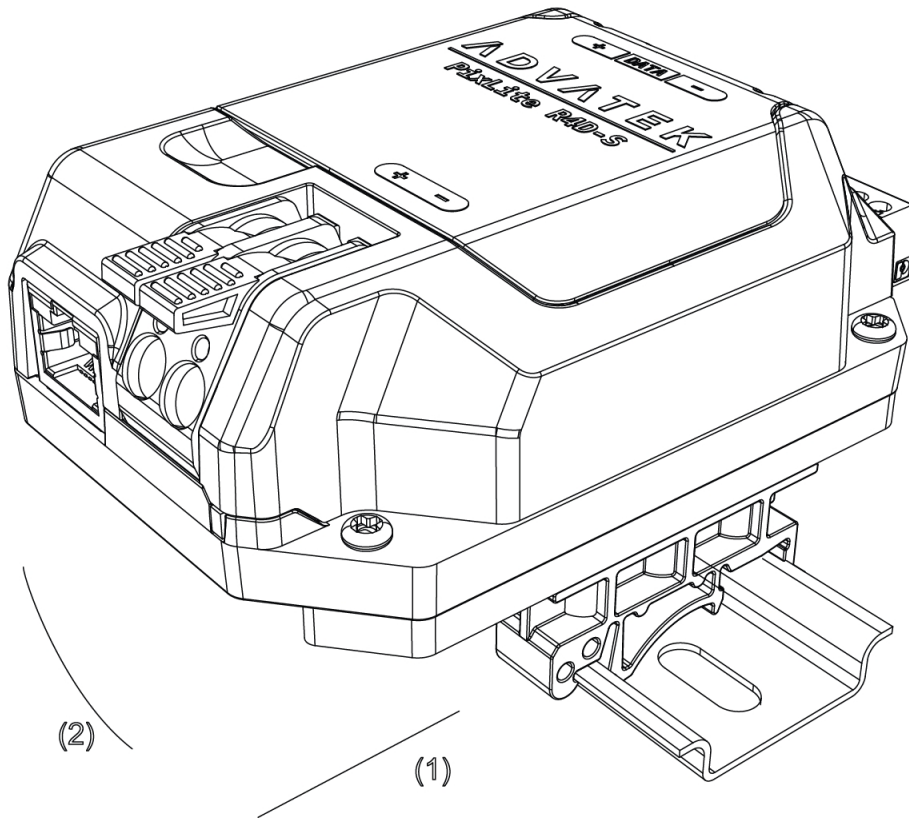

# 5 - Electrical Connections

## 5.1 - Supplying Power

Power is applied to the PixLite R4D-S via the large lever clamp connector. The levers should be lifted up for wire insertion and then clamped back down, providing a highly robust and secure connection. Ensure the wire's insulation is stripped back 11-12mm, so that the clamp does not rest on the insulation when closing the connector. Polarity for the connector is clearly marked on the lid, as shown in [Figure 5](#) below. The type of wire required for supply connection is 4.0mm<sup>2</sup>, 10AWG, VW-1.

Figure 5: Location of Power Input

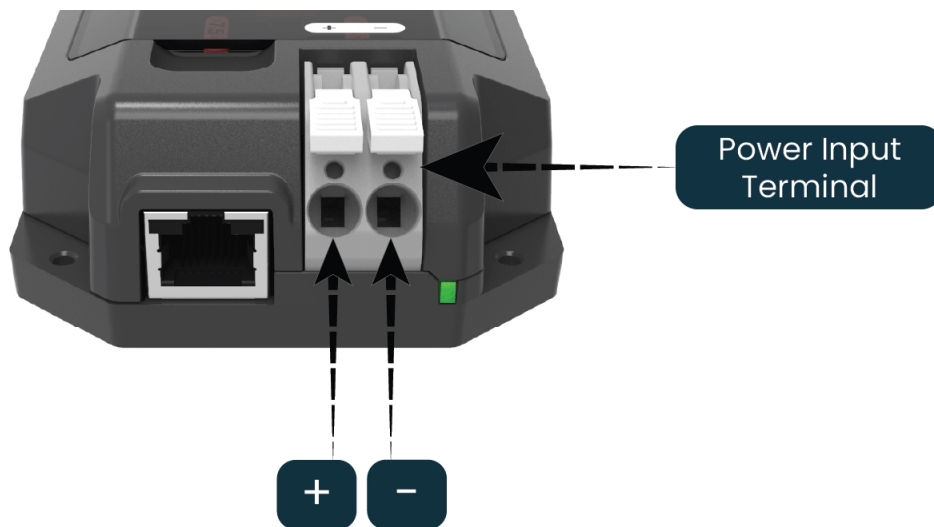

## 5.2 - Output Fuses

Each individual output is protected by a mini blade fuse. The PixLite R4D-S comes with 7.5A fuses by default. You may use any value of fuse, up to and including 7.5A, depending on your specific application.

Each output is rated at a maximum of 6A, and must not be operated in excess of 6A. The fuse is rated to 7.5A to protect against inadvertent overcurrent or short circuit and is not an indication of rated current.

If a fuse needs replacing, a suitable replacement fuse is of type "F7.5A E 32V". An additional spare fuse is also provided for quick replacement which can be accessed by opening the lid, as shown in [Figure 6](#) below.

Figure 6: Internal View of the PixLite R4D-S

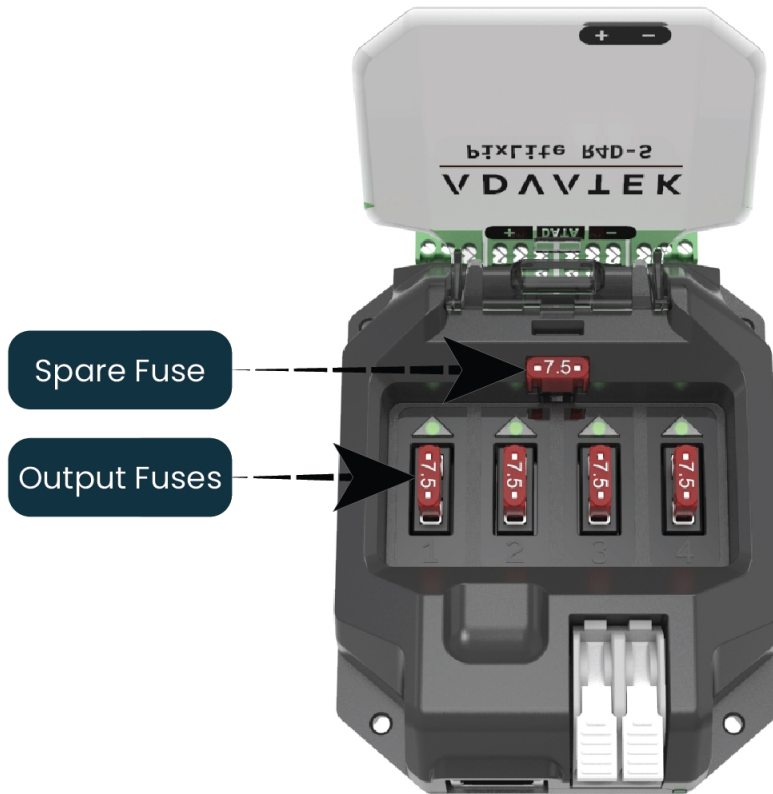

Logic power is automatically regulated from the power input. Simply connect your DC power supply in accordance with specifications listed in [Section 7.1](#) to the power input.

### 5.3 - Data Input

Data from the transmitter is connected via the RJ45 port located on the front panel of the unit, as shown in [Figure 7](#) below.

Figure 7: Position of Data Input

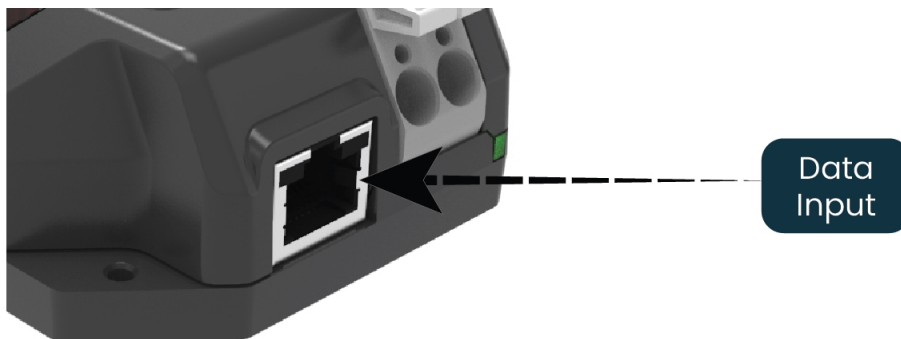

Receivers are connected to the transmitter via the RJ45 jacks on the rear panel of the PixLite transmitter. Each jack is labelled with its output number. These ports are not Ethernet network ports, and should not be connected to any networking equipment. They are specifically designed to

connect a PixLite transmitter with a PixLite receiver. The cable used should be twisted pair cable with nominal 100 Ohm characteristic impedance (e.g. Cat 5 or Cat 6 cable), and can be up to 300 meters in length.

There are various system topologies that can be achieved by pairing a specific transmitter with a specific receiver. Not all permutations can be connected. The pairings that are supported by this device are shown in [Figure 8](#) below.

*Figure 8: Connecting Receivers to Transmitter*

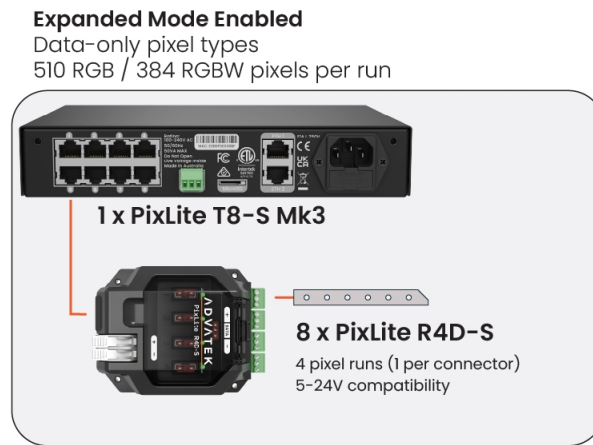

## 5.4 - Connecting Pixel LEDs

The pixel lights are connected directly via the 4 pluggable screw terminal connectors on the rear of the unit. Each connector is labelled with its output channel number (1-4) and on the top of the lid the pin-out is clearly marked. Simply wire your lights into each screw terminal and then plug them into the mating sockets.

Since the PixLite R4D-S product has data only outputs (no pixel clock lines), it takes advantage of the transmitter's Expanded Mode. In expanded mode, the clock signals are re-purposed for data signals instead. This means the receiver effectively has twice as many pixel outputs than the PixLite R2 (4), but half as many pixels per output can be run.

The cable length between the output and the first pixel should not exceed 15m.

*Figure 9: Pixel Output Pinout*

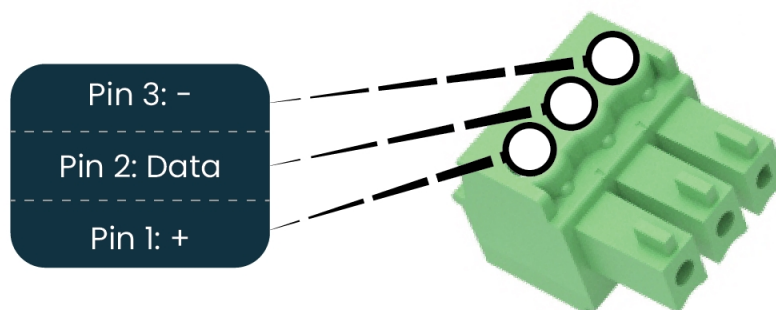

# 6 - Operation

## 6.1 - Start-up

When power is applied to the receiver, the green power LED in the bottom right-hand corner on the front panel should be illuminated, as shown in [Figure 10](#) below.

*Figure 10: Position of the Power LED*

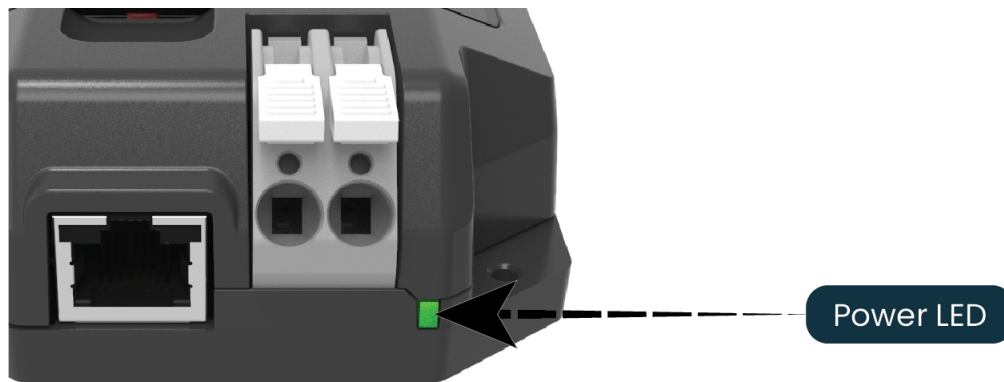

If pixels have been correctly connected to the outputs and the data cable is connected to the transmitter and valid data is being sent, you should see the pixels turn on.

## 6.2 - Indicator LEDs

Each fuse is paired with a green LED which indicates the condition of the fuse. If the fuse is good, the LED will be on. If the fuse has been blown or is not connected, the LED will be off. This feature offers a quick method for determining the state of each fuse, however in environments where these LEDs are needed to be turned off, a switch is located underneath the spare fuse that will turn off this feature. If the switch is pushed to the right, it is off, and all indicator LEDs and the power LED will always be off. This switch is shown in [Figure 11](#) below.

Figure 11: Position of Indicator LEDs and Switch

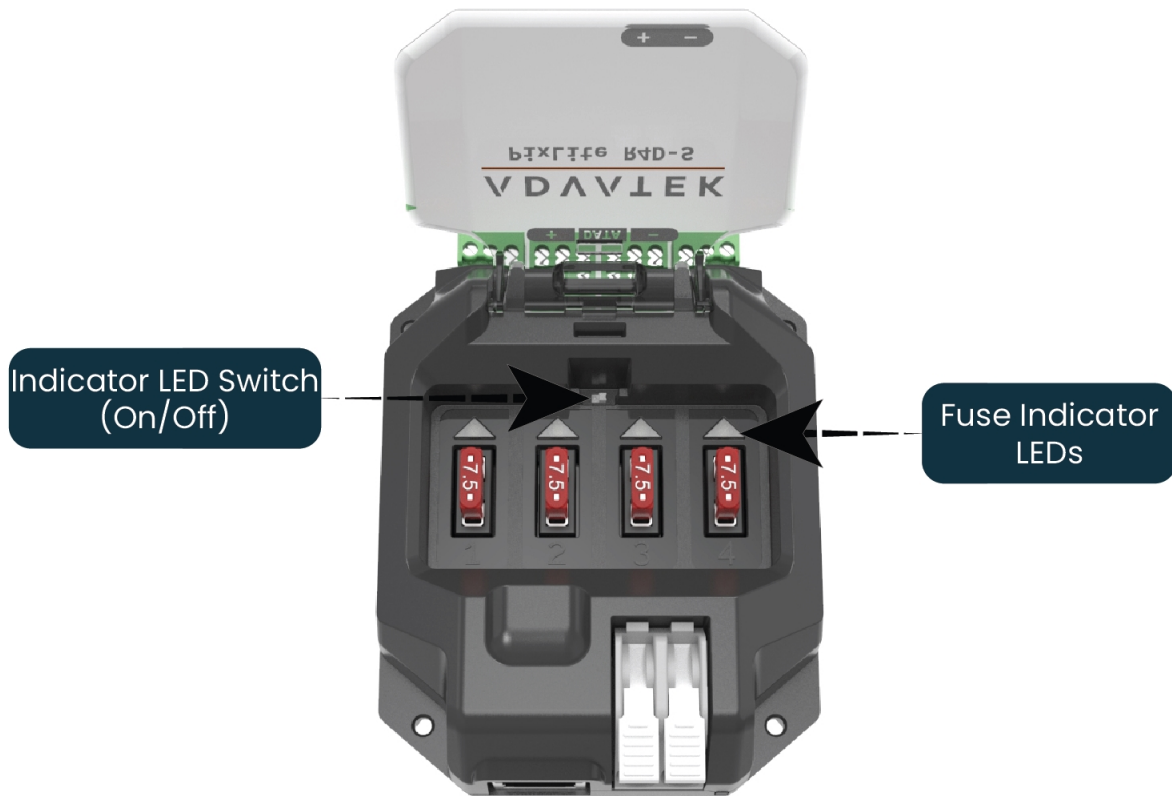

## 6.3 - Outputs

The number of pixels per output is configured in the transmitter device and may vary depending on the pixel capacity of the specific device.

The refresh rate of the pixels will depend on the operating frequency of the specific pixel chip type. Refer to the user manual of the PixLite Transmitter device for more information about this topic as the Transmitter will be responsible for the refresh rate of this receiver.

# 7 - Specifications

## 7.1 - Operating Specifications

The table below specifies the recommended operating conditions for a PixLite R4D-S receiver.

For a full list of specifications, refer to the product datasheet.

Parameter	Value/Range	Units
Input Voltage Range	5-24	V DC
Per Output Fuse Rating	7.5	A
Maximum Current Per Output	6	A
Total Maximum Current	24	A
Max Logic Current Consumption @ 5V	150	mA
Ambient Operating Temperature	-20 to +55	°C
Storage Temperature	-20 to +55	°C

## 7.2 - Mechanical Specifications

The PixLite R4D-S receiver has dimensions as below.

Dimension	Metric	Imperial
Length	95mm	3.7"
Width	78mm	3.1"
Height	33mm	1.3"
Weight	0.2kg	0.4lbs

Figure 12: Receiver Mechanical Specifications

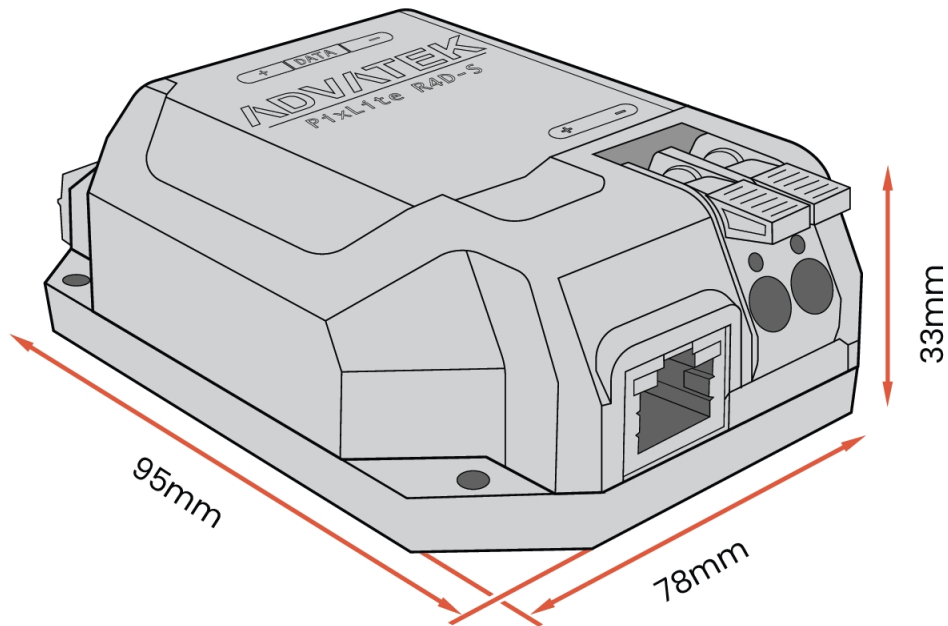

## 7.3 - Fault Protection

The PixLite R4D-S features notable protection from potential damage due to various types of faults. This makes the device extremely robust and reliably able to withstand installation and operation even in harsh environments.

ESD protection is present on all data input lines and on all pixel output lines.

The data input port is protected against faults of up to +/- 48V between signal and common. All pixel output lines are protected against faults of up to +/- 24V.

The PixLite R4D-S itself is protected against damage from reversed polarity power input. However it does not provide external reverse polarity protection for any loads that you may have connected to the pixel outputs.

# 8 - Troubleshooting

## 8.1 - No Power LED

Ensure that your power supply is supplying correct voltage. Additionally, ensure that it can supply enough current to drive the lights that are connected. You should also try disconnecting the pixel outputs and see if the receiver then turns on.

## 8.2 - No Pixel Control

Check that the correct pixel IC type has been configured on the transmitter unit. Also check the physical wiring and pinout of the pixels, as well as the output fuses. Ensure that the green 'fuse good' indicator LEDs under the lid compartment are all visible (one per output channel). If any are off, replace any blown output fuses as required.

## 8.3 - Other Issues

For the latest information, and industry advice, you can refer to our online guides here:

[www.advateklighting.com/blog/guides](http://www.advateklighting.com/blog/guides)

You'll find information on management and configuration of the device, including its internal SHOWTime feature set in the PixLite Mk3 Management Guide:

[www.advateklighting.com/downloads/user-manuals/pixlite-mk3-management-guide](http://www.advateklighting.com/downloads/user-manuals/pixlite-mk3-management-guide)

For any other questions, you can reach out to our support team at the link below:

[www.advateklighting.com/contact](http://www.advateklighting.com/contact)  
[support@advateklighting.com](mailto:support@advateklighting.com)

# 9 - Disclaimer

If you require support or warranty, please refer to [Section 8.3](#) for information on creating a support ticket. You must be issued with a return authorization by Advatek support staff before returning any product.

This device is only suitable for use in accordance with the specifications. This device is only suitable for use in an indoor environment which is protected from the weather unless a conformal coating option has been selected. In case of products protected by conformal coating, the device can be used outdoors, provided it is protected from the weather using an enclosure suitable for the environment.

The PixLite R4D-S receiver is supplied with a 5-year limited warranty and a repair/replacement guarantee. Please see the terms and conditions on our website for more information.

The PixLite R4D-S has been tested against and independently certified as compliant with the standards and directives listed in the table below.

Audio/Video and ICTE - Safety Requirements		UL 62368-1
Radiated Emissions		EN 55032 & FCC Part 15
Immunity for ITE EN 55024	Electrostatic Discharge	EN 61000-4-2
	Radiated Immunity	EN 61000-4-3
	Power Frequency Magnetic Field Immunity	EN 61000-4-8
Restriction of Hazardous Substances		RoHS 3

Through testing to the above standards, the PixLite R4D-S has the certifications and marks listed in the table below.

Certification	Relevant Country
ETL Listing (UL 662368-1)	North America and Canada
CE	Europe
FCC	North America
ICES3	Canada
RCM	Australia and New Zealand
UKCA	United Kingdom

**Warning:** Changes or modifications to this unit not expressly approved by the party responsible for compliance could void the user's authority to operate the equipment.

**Note:** This equipment has been tested and found to comply with the limits for a Class A digital device, pursuant to part 15 of the FCC Rules. These limits are designed to provide reasonable protection against harmful interference when the equipment is operated in a commercial environment. This equipment generates, uses and can radiate radio frequency energy and, if not installed and used in accordance with the instruction manual, may cause harmful interference to

radio communications. Operation of this equipment in a residential area is likely to cause harmful interference in which case the user will be required to correct the interference at their own expense.

This product has been manufactured by:

Advatek Lighting Pty Ltd  
U1, 3-5 Gilda Court  
Mulgrave, 3170  
VIC, AUSTRALIA